



INSTRUCTION MANUAL



TAH 85 PRO

12V

This Technical Manual is a guide to assist the user in the assembly and in the starting of his new trap.

Available from your LAPORTE Dealer, in printed form or on CD-ROM, or reference our web site and free "Download" to your PC

SAFETY FIRST

**DANGER - THESE MACHINES CAN CAUSE SERIOUS INJURY!
READ INSTRUCTIONS THOROUGHLY BEFORE ATTEMPTING TO INSTALL OR OPERATE!**

1. ☞ BEFORE :

- Installing the trap,
- Connecting power,
- Lubricating,
- Loading the magazine or
- Making any adjustments

☞ Be sure that the throwing arm is in the safe, uncocked position or that the mainspring is disconnected, the "ON-OFF-UNCOCK" toggle switch on the electrical control box is in the "OFF" position, and the machine is disconnected from the power source.

NOTE: The "Decocked" position mentioned throughout this manual refers to the position of the throwing arm.

2. All personnel required to operate the trap, or load targets into the magazine, should read this instruction manual and be trained by someone knowledgeable as to the safe operation of the equipment.

3. Do not leave trap cocked when not in use. Not only is this practice very hazardous, but, as the mainspring is stretched, its useful life will be shortened.

4. **Only one person should operate the trap at any one time.**

NOTE: TO DECOCK THE THROWING ARM AND PLACE THE TRAP IN A SAFE CONDITION, MOVE THE "ON-OFF-UNCOCK" TOGGLE SWITCH, ON THE ELECTRICAL CONTROL BOX, TO THE "UNCOCK" POSITION, THEN TO THE "OFF" POSITION. THE THROWING ARM SHOULD 'FIRE' AND STOP IN THE "UNCOCKED" POSITION OUT IN FRONT OF THE TRAP. THEN DISCONNECT POWER FROM THE ELECTRICAL CONTROL BOX.

5. Do not operate the trap without the safety guard ring installed on the trap as illustrated in this manual. This safety guard defines the danger zone of the throwing arm rotation.

6. Do not lift or move the trap by the throwing arm or the safety guard. Do not lean on the safety guard or place any weight on it such as box of targets.

7. Safety glasses must be worn by all personnel within close proximity to the trap to prevent eye injury from flying target fragments.

8. Always keep children and animals away from the trap machine.

9. Before turning on any switches, move to a safe position at the left rear of the trap and make sure that no one is within the danger zone in front of the trap. High-speed fragments from broken targets being thrown, may fly outside the normal target danger zone, even backwards. (They may even rebound off traphouse sides etc.). When trap is cocked and ready for use, always leave the area by keeping to the rear of the machine.

10. Before approaching the trap, for any maintenance, adjustments, or for the loading of targets, be sure the trap is turned off with the "ON-OFF-UNCOCK" toggle switch on the electrical control box in the "OFF" position, and the throwing arm is in the "Decocked" 8:45 position.

START-UP INSTRUCTIONS

This trap may be installed on LAPORTE trolley or a wooden or concrete platform.
Secure the trap to the base using suitable screws and bolts for the type of platform being used.

1. Install the spring (see Arming Spring notice)
2. Install the Safety Guard for the throwing arm (see notice).
3. Install the standard clay magazine (see notice) :

Insert a pile of clays from the top of the magazine and make sure that the bottom clay is situated correctly on the clay holding mechanism.

3. Connect the "Pull Cord".

Plug the white 4-pin plug of the cable release onto the female plug on the moulded box and latch the clip to hold this in position.

4. Electrical connection (see notice):
Control the polarities "+" and "-" on the power supply.
5. Position the "ON-OFF-UNCOCK" switch from the OFF position to the ON position.

Press once on the "PULL"

- a clay falls and the arm cocks. Press a second time to fire and re-cock the machine.

Repeat this last operation a few times in order to establish the correct distance and trajectory.

Uncock the machine.

Before any modification :

Move the switch marked "ON-OFF-UNCOCK" on the electrical control box from the "ON" position to the "UNCOCK" position and then to the "OFF" position (Decocking the trap)

6. Locking of the Vertical movement (TAH model) – see notice.
7. Locking of the Horizontal movement (TAH model) – see notice.
8. The test procedure is now complete.

IMPORTANT: Before any subsequent manipulations, stand behind the machine in the "safety position" and make sure that no-one is standing in the "firing zone".

TROUBLE SHOOTING

CAUTION: BEFORE MAKING ANY CHANGES OR ADJUSTMENTS MAKE SURE THE THROWING ARM IS IN THE SAFE UNCOCKED POSITION.

1. THE COCKING MOTOR WILL NOT START

Electricity is not connected.

The circuit breaker is off or the fuse has blown. Move the switch marked "**ON-OFF-UNCOCK**" on the electrical control box to the "**OFF**" position. Remove the cover of the control box and see if the **BLACK** button on the circuit breaker has "Popped". If it has, press it in. Check the fuses. If the circuit breaker continues to "kick out", or if fuses continue to blow, check all wiring and electrical supply to locate the cause before continuing.

Electrical connections are dirty or loose.

The cocking motor has burnt out.

The electrical connections do not comply (see Start-Up Instructions).

2. THE MACHINE IS COCKED BUT DOES NOT FIRE

The main spring is broken.

There is no electrical supply.

The "Pull" switch or remote release system is not working.

The battery in the Optional Radio Control transmitter is flat or exhausted, and needs replacing.

The switch on the "**ON-OFF-UNCOCK**" is in the **OFF** position.

The throwing arm is blocked by two clays or by fragmented clays. **WARNING:** At this time the throwing arm will be pressing against the targets with **TREMENDOUS PRESSURE**. When uncocking the trap using "Manually Uncocking", be **EXTREMELY CAUTIOUS**, as the throwing arm will release **VERY** fast. The target(s) on the throwing plate will most probably shatter throwing target fragments in all directions.

The throwing arm is bent or broken and subsequently jammed against some part of the trap, e.g. the mobile throwing plate, the magazine base. **THIS IS A VERY DANGEROUS CONDITION!** As you cannot "Decock" the machine. The arm will have to be removed.... Call LAPORTE for help.

3. THE THROWING ARM DOES NOT STOP DECOCKING AND THROWING TARGETS.

The cocking micro-switch is broken or out of adjustment, and causes the cocking motor to run continually during 2 cycles. At the third one, the machine decocks and the motor stops running.

The "PULL" button is stuck, or the cable is damaged.

4. ABNORMAL NOISES

Check all bolts for tightness.

The mainspring does not have sufficient tension on it, and the coils are touching each other: **it is imperative that when the spring is totally loose, the coils do not touch**. If they do, this could break the main body.

The gearbox is low on oil.

The one way bearing is worn out or damaged.

5. THE TARGETS BREAK IMMEDIATELY WHEN FIRING

The targets were damaged prior to loading.

The targets were damaged during loading.

Mixed targets (different diameters in it stack i.e. 107-109-110mm)

The rubber is damaged or worn.

The throwing arm is bent. It can be straightened without removing it. Check that the rubber is always at the same distance from the throwing plate. Uncock the throwing arm and take out the mainspring before this inspection and adjustment.

The throwing plate is damaged. Check edges of plate for 'nicks' and file smooth if necessary.

The throwing plate is dirty or has clay target pitch build up resulting in the target not being positioned correct at cocking time. Clean with solvent or sand it.

The throwing plate is loose.

Check that nothing is in the way of the target trajectory.

If you have any questions or need assistance, please call :
LAPORTE® Head Office Phone : +33 493 65 77 77 Fax : +33 493 65 77 78
e-mail export@laporte-shooting.com www.laporte-shooting.com

6. The motor starts turns but the machine does not cock.

Check the state of the chain.

7. The motor turns but the machine does not rotate.

Check the state of the chain, cable, and the spring.

8. Two clays fall from the magazine

Mixed clays (different diameters in same stack i.e. 107-109-110mm)

Check the distance between the clay and the clay block.

6. The targets do not come out of the magazine

The targets are stuck together. Separate them before putting them in the magazine.

Mixed targets. (different diameters in same stack i.e. 107-109-110mm)

Magazine rods are damaged or bent and are restricting the vertical movement of the target stack.

The magazine support base is damaged.

The magazine is twisted.

The adapter knives are not adjusted correctly (see notice)

Check the distance between the clays and the clay block.

FEATURES AND DESCRIPTIONS

LAPORTE® Trap models MINI TAH 85 PRO and MINI PC 85 PRO are fully automatic trap and combines simplicity and reliability, robustness and lightness (aluminium body), trajectory regularity and rapid adjustment. These models allow you to throw rapid and continuous clays (re-cocking in 0.6 seconds) and offer the possibility to quickly change the type of clay pigeon (Standard, Battue, Mini or Midi).

SPECIFICATIONS:

- COMPANY WITH PROVEN RECORD OF SUCCESS

- 70 Years of Trap design
- Supplier to Olympic games
- Only traps on market endorsed by NSSA (National Skeet Sporting Association, USA), NSCA (National Sporting Clay Association, USA), FITASC (International Federation for Shooting Sport), and by appointment to Her Majesty the Queen of U.K.

- UNCOMPLICATED DESIGN

- Simple to use
- Minimum moving parts
 - Easy maintenance and parts replacement

- MAGAZINE:

- 1 column
- 85 target capacity (Standard, Midi and Mini) And 135 (Battue)
- Top loading

- TARGET:

- Standard with optional adapter for Midi (90 mm), Mini (60mm) or Battue.

- ALUMINIUM CASTINGS. High quality epoxy paint finish (does not rust)

- Lightweight, easily moved

- PRE-WIRED ELECTRICAL CONTROL BOX.

- Easily maintained electrical parts

- SAFETY

- Full safety guard of the throwing arm.

Note: Must always be assembled on Trap

- Encircles whole area traversed by throwing arm

- ONE WAY BEARING ON THROWING ARM

- Stops the throwing arm in 3/4 cocked position
- Reduces vibrations
- Enables faster 'cocking'

- TRAJECTORY:

- Perfect from start to finish

- THROWING DISTANCE:

- From 20 m to 90 m (black spring – red springs)

- TRAJECTORY MOVEMENTS:

- Combined horizontal and vertical angles (TAH model)
 - Horizontal movement only (TAH model)
 - Vertical movement only (TAH model)
 - Fixed position (PC and TAH)

- TARGET RELEASE:

- By cable.
- Or on option : by radio remote control or voice release system upon request.

- VOLTAGE: available in 12V.

- **RE-COCKING:** 0.6 seconds. The motor only operates for a short time during the re-cocking sequence and therefore, uses very little power.

- WEIGHT: 69 Kg Mini TAH/49 Kg. Mini PC

If you have any questions or need assistance, please call :
LAPORTE® Head Office Phone : +33 493 65 77 77 Fax : +33 493 65 77 78
e-mail export@laporte-shooting.com www.laporte-shooting.com

RECOMMENDED safety position when the machine is cocked.

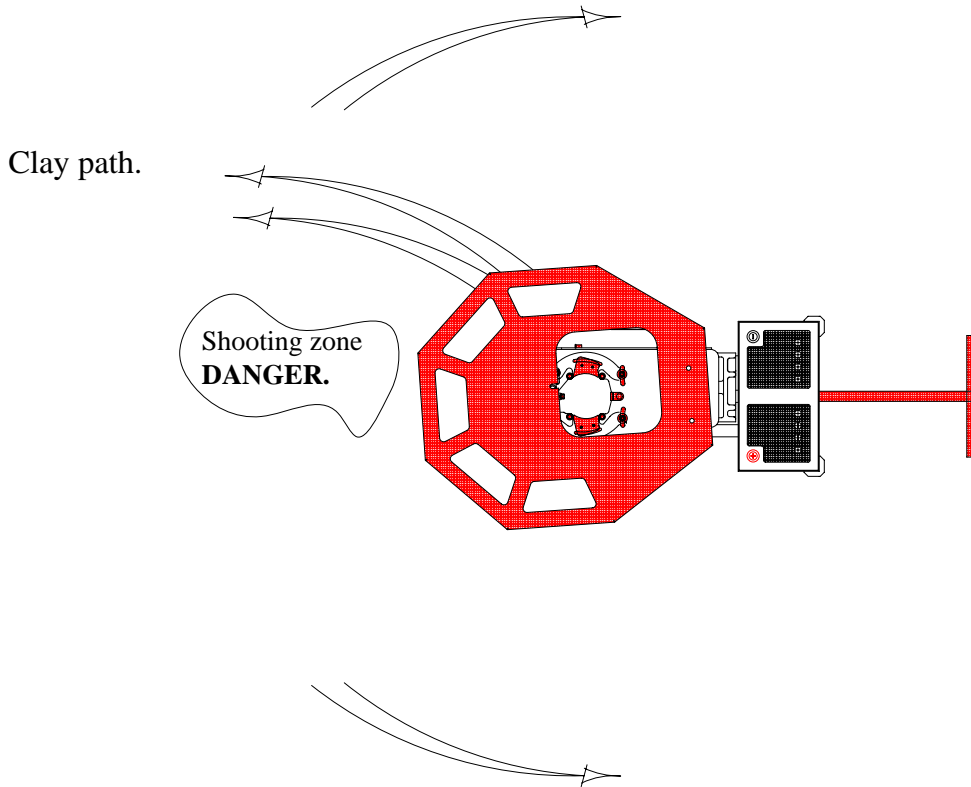

Throwing arm in **cocked** and uncocked position.

Throwing arm in UNCOCKED position:

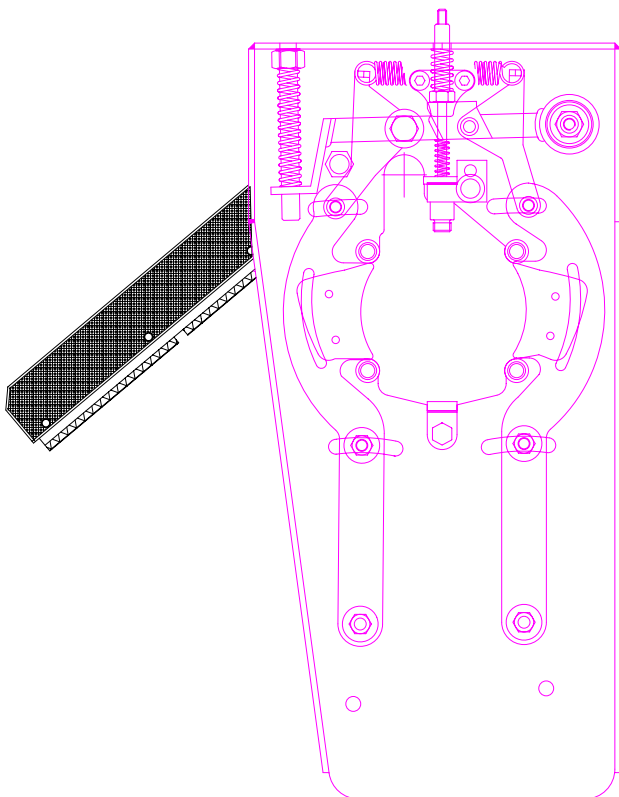

Throwing arm in COCKED position:

WARNING DANGER !!!

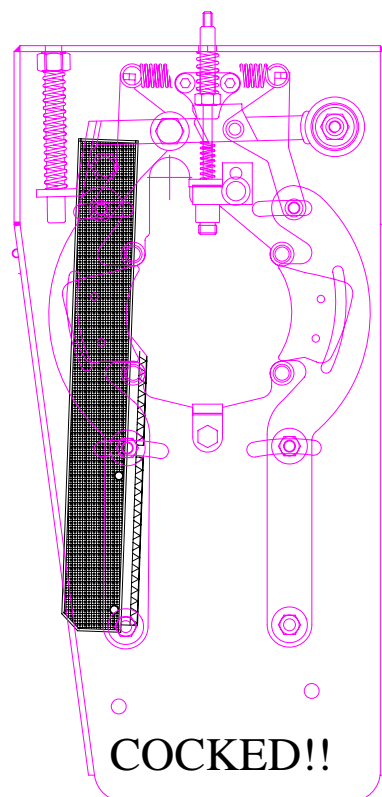

Arming spring.

Position of the arm when the machine is delivered:

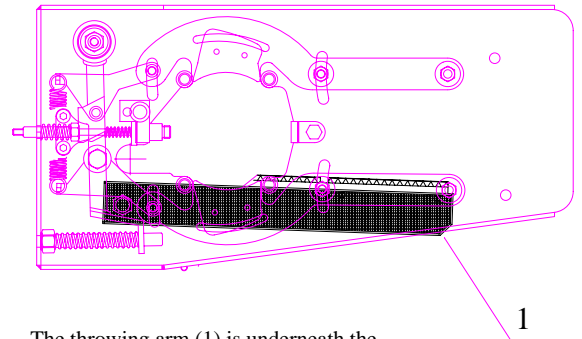
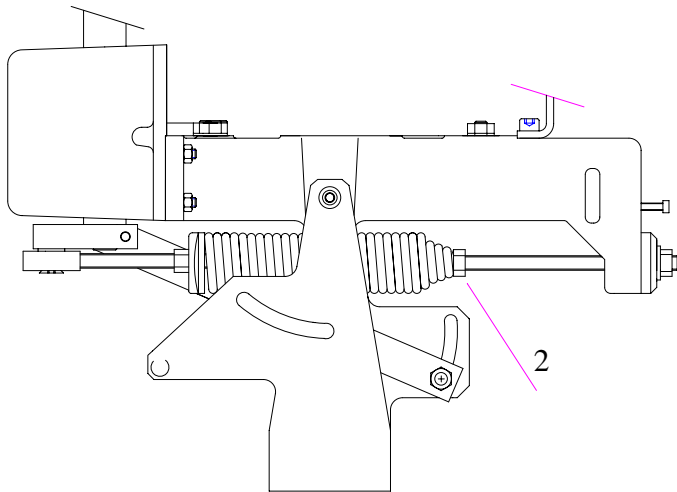

The throwing arm (1) is underneath the machine, the spring is (2) not extended.

1. Position the arm in front of the machine:

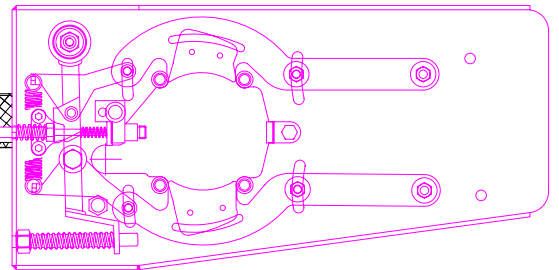
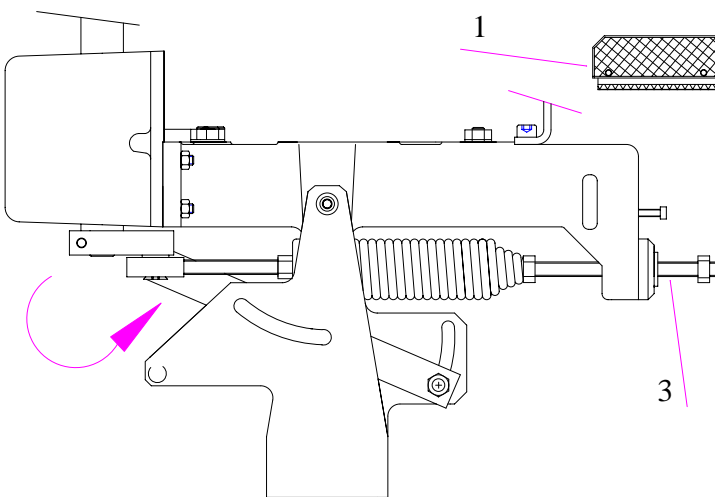

Pull the threaded rod (3) to move the arm (1) in front of the machine.

2. Pull the spring:

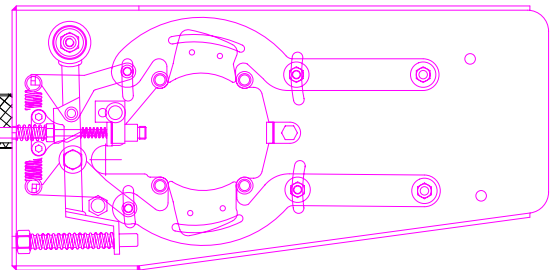
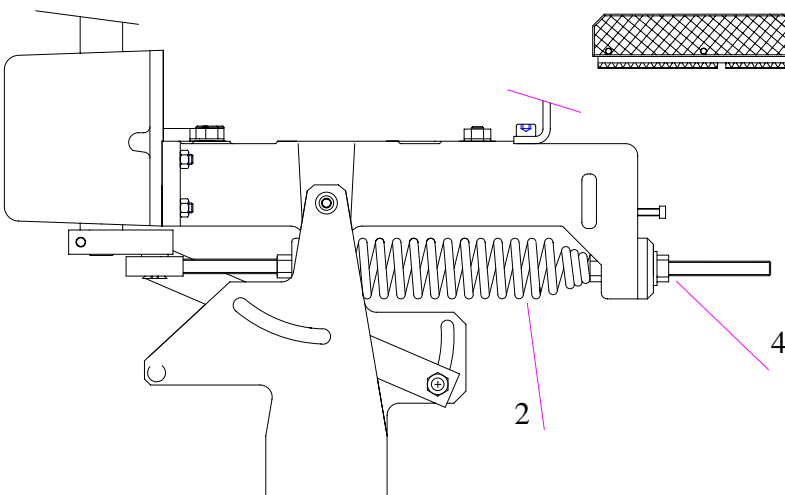

Screw the nut (4) to extend the spring (2).

To dismantle the spring:

1. Uncock and disconnet the machine.
2. Unscrew the nut completely (4).

Adapter kit for clay pigeon Ø110 (standard)

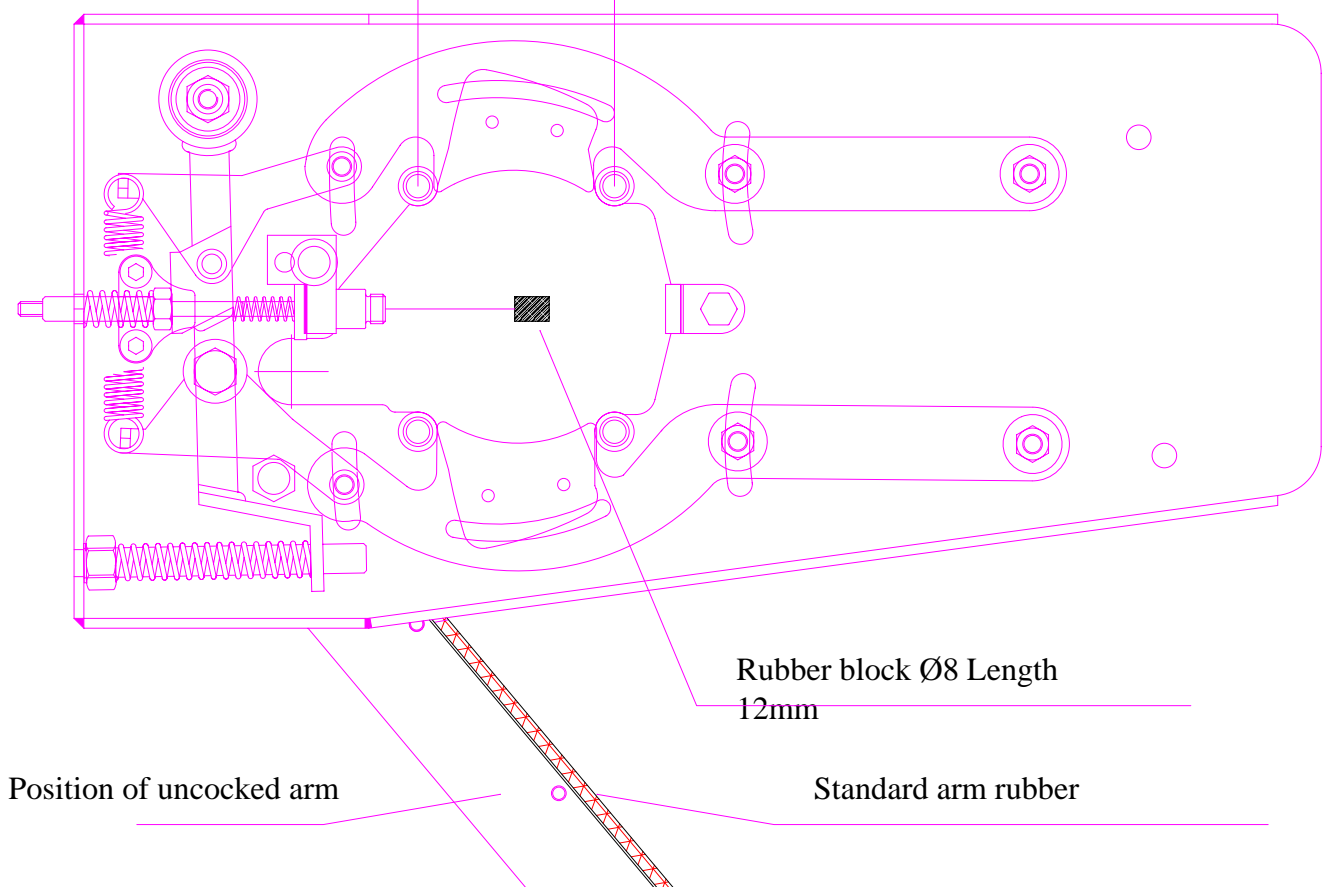
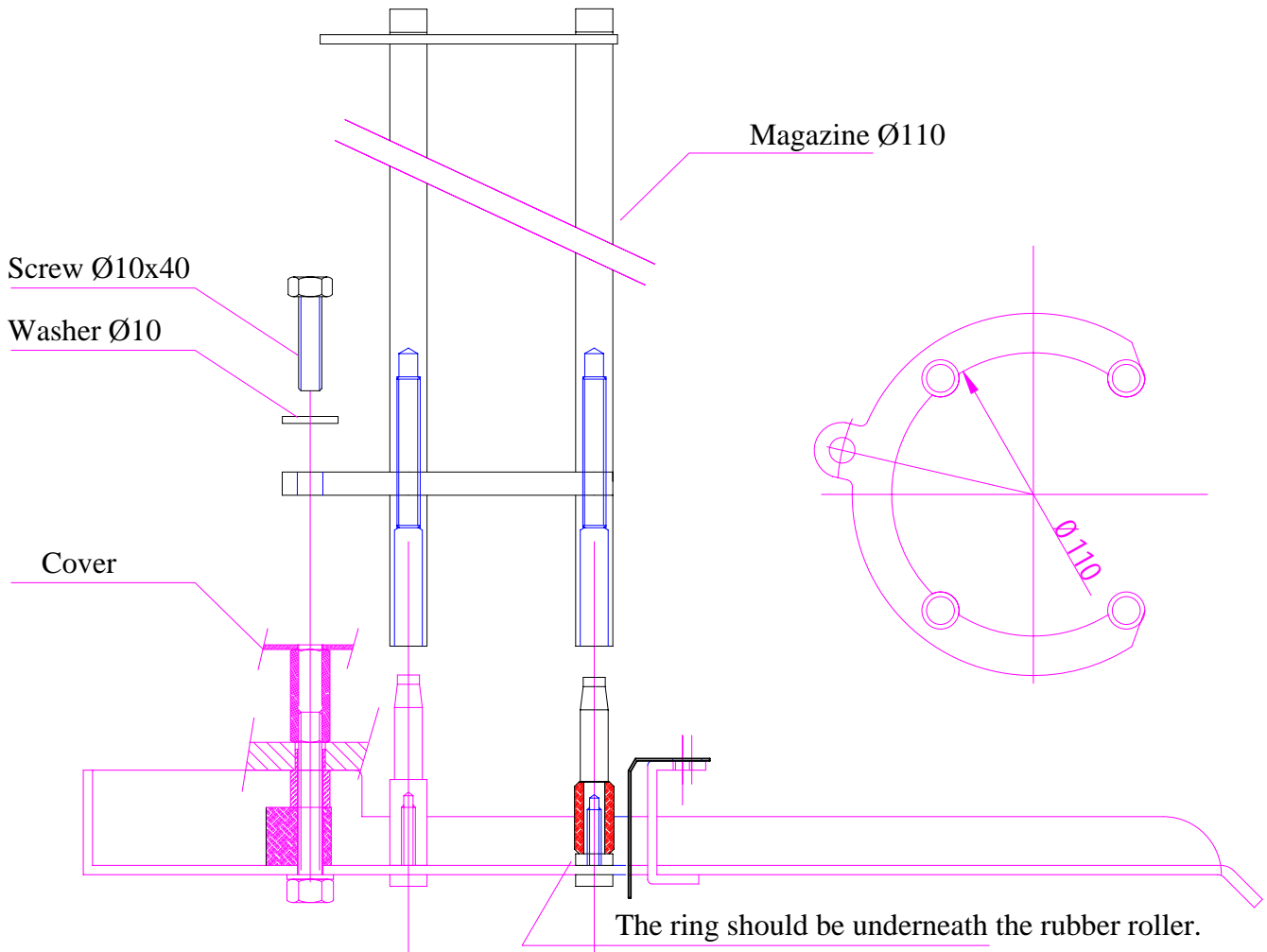

Adapter kit BATTUE Ø110

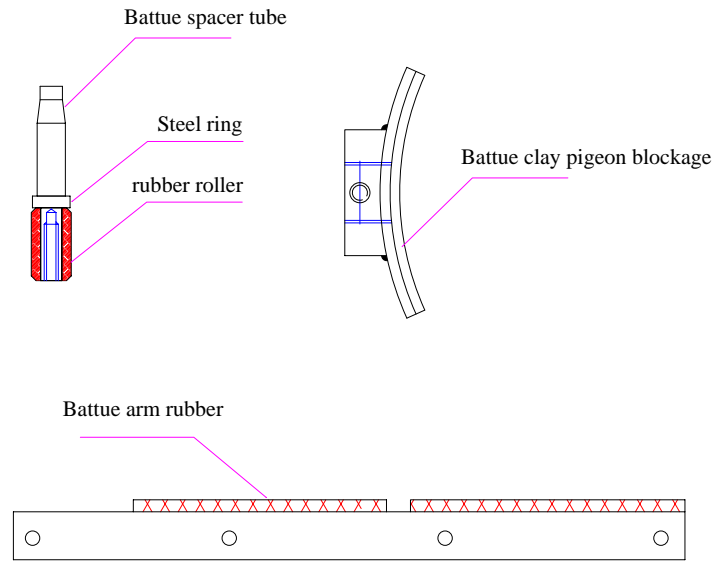
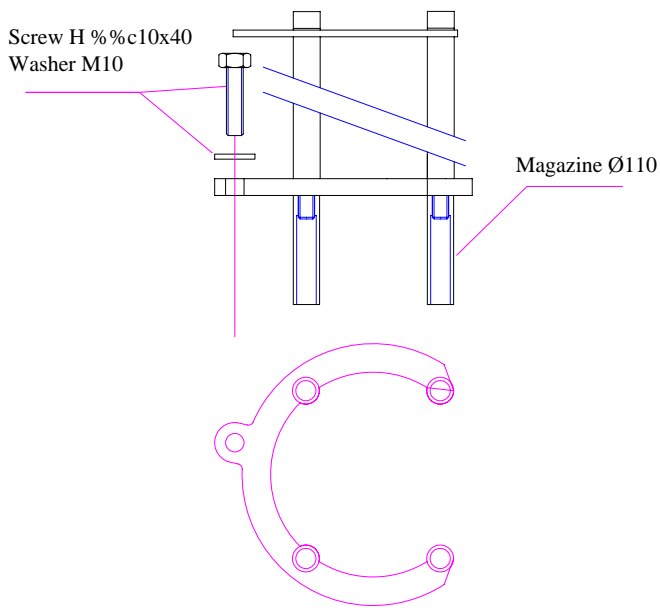

STEP N°1.

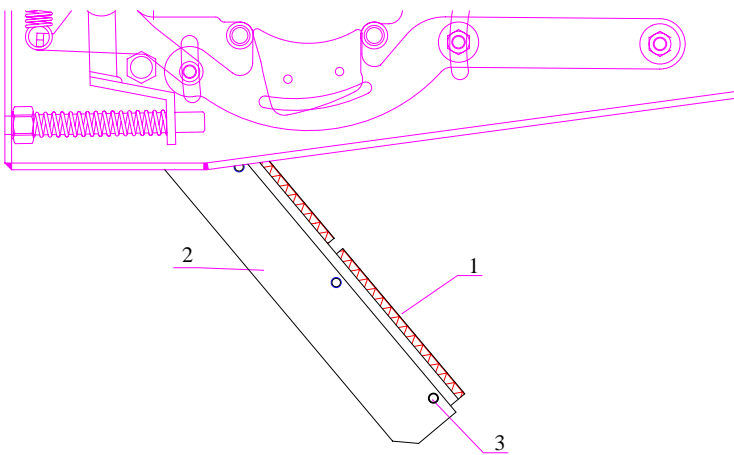

1. Dismantle the standard arm rubber on the throwing arm (2).
2. Position the Battue arm rubber (1) on the arm (2) in place of the standard arm rubber.
3. Screw in the 4 screws H M5x10 (3).

STEP N°2.

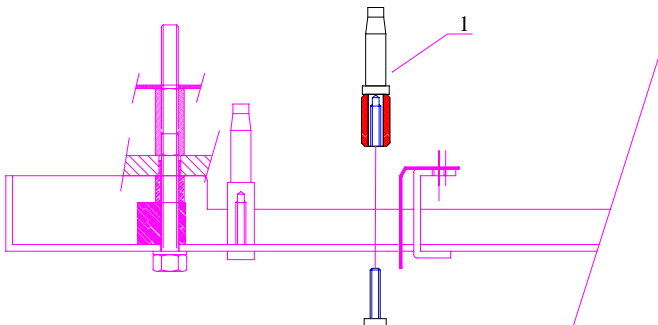

1. Unscrew the two standard spacers (with rubber roller).
2. Position and screw the two Battue spacers (1).
Warning !!! On the Battue spacers the steel ring is placed on top of the rubber roller.

STEP N°3.

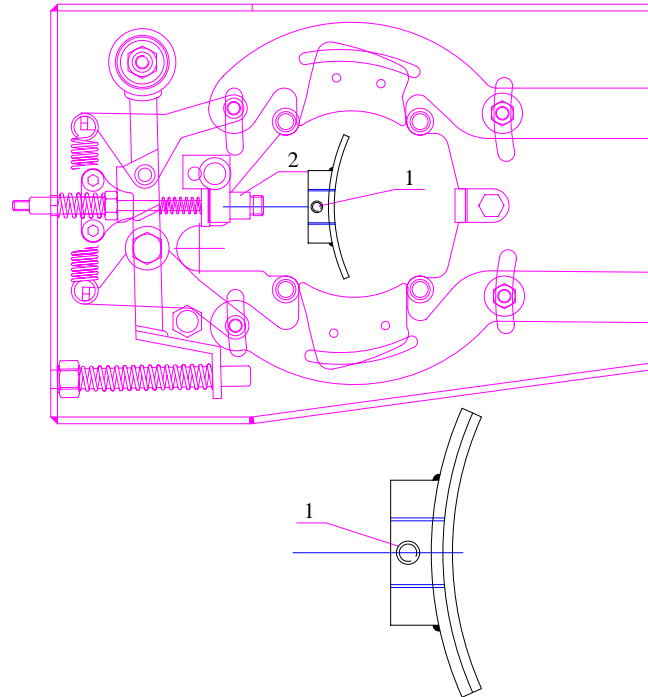

1. Screw the Battue clay blockage on the standard clay blockage (2).
2. Position the pointed screw (1) upwards, as indicated.
3. Tighten the pointed screw (1).

STEP N°4.

1. Position the standard magazine Ø110 as indicated in the notice for the standard clay adapter kit.

Adapter kit for clay pigeon Ø90

Screw Ø10x40
Washer Ø10

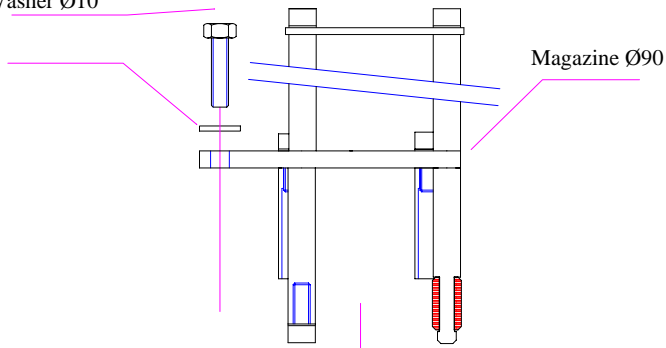

Magazine Ø90

Blockage Ø90

Rubber Block

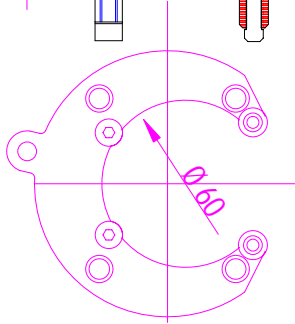

Left plate.

4 Screw FHC Ø5x10.
4 Nuts Ø5

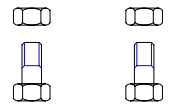
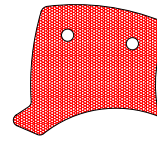

Right plate

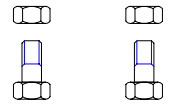
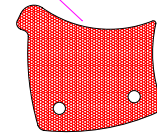

STEP N°1.

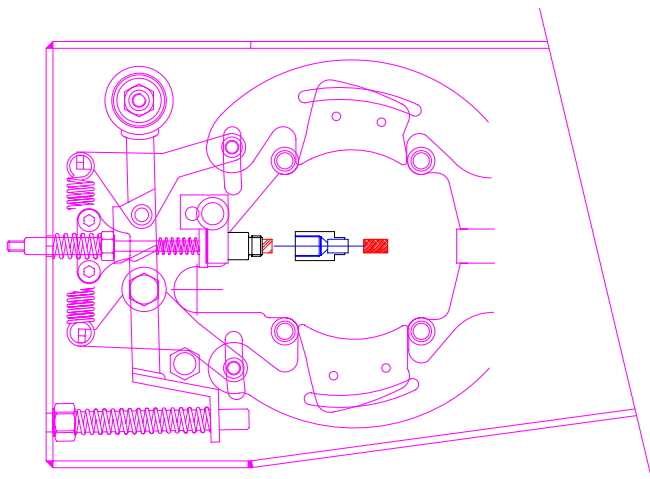

Screw the pigeon block Ø90 on to the blocking system for the standard clay pigeon. As indicated on the picture. Do not remove the rubber block.

STEP N°3.

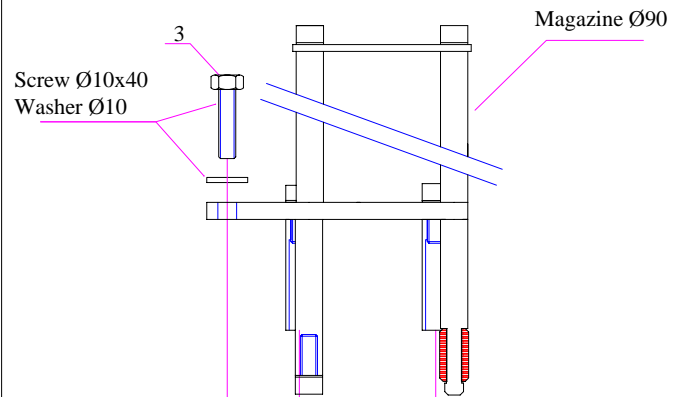

3
Screw Ø10x40
Washer Ø10

Magazine Ø90

STEP N°2.

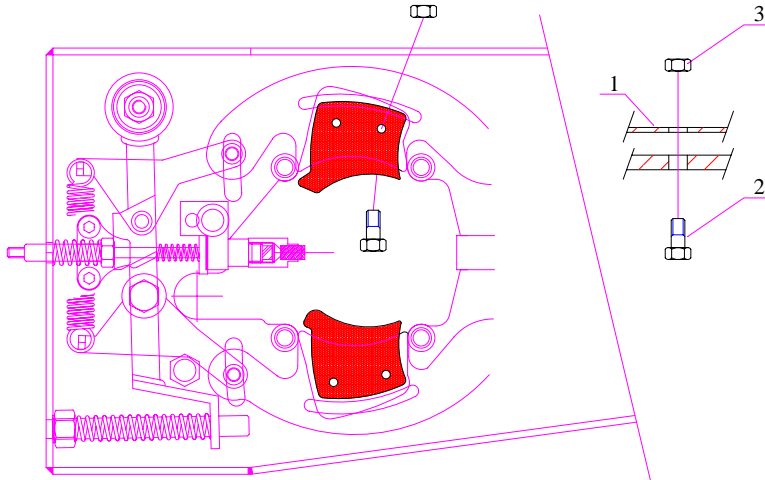

1. Position the plates (1) exactly as illustrated.
- 2/ Screw the plates (1) with the 4 Screws FHC Ø5x10 (2).
Warning !!! Nut (3) on top.

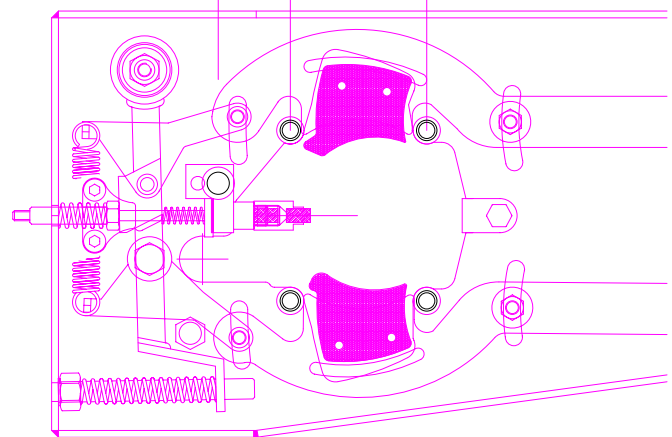

1. Position the magazine Ø90 in the place of the standard magazine.
2. Tighten the Screw HM 10x40 (3).

Setting of the knife when using the kit Ø90.

It is imperative to uncock and disconnect the machine before any manipulation.

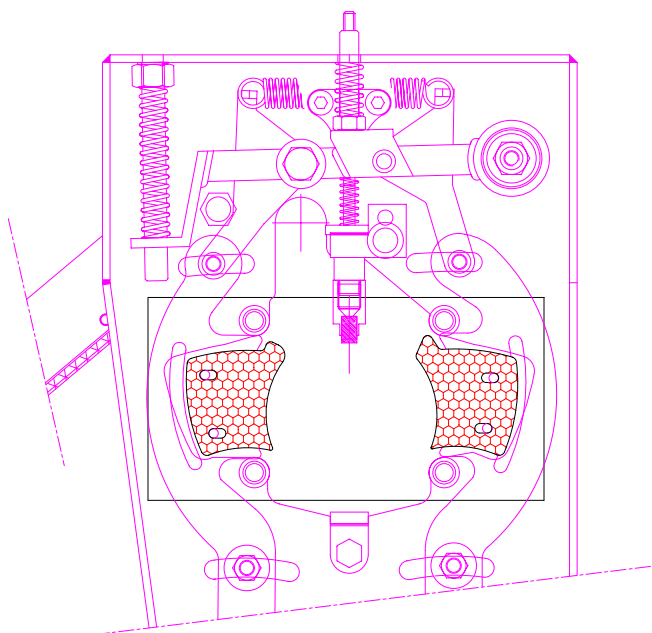

Dessin n°1

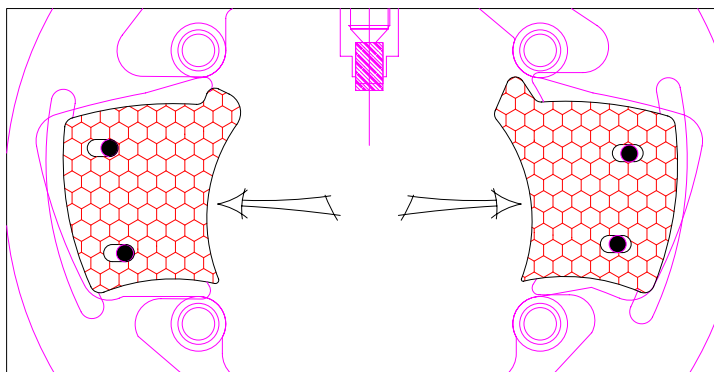

1. Put the two knives in place (as illustrated) and push them a maximum outwards.
2. Tighten the 4 nuts Ø5.
3. Throw a testing clay; the clay should free simultaneously by the two knives and fall flat. If the clay does not fall flat, make the adjustments. (See case n°1 or case n°2)

Case n°1: The clay is held on the right side and the left side is free.

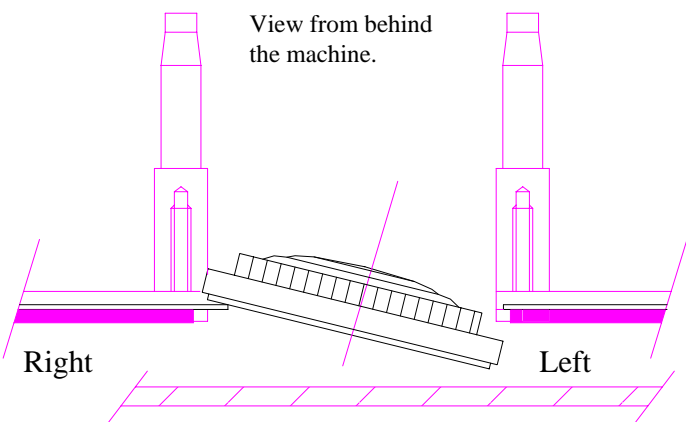

Drawing n°2

Case n°2: The clay is held on the left side and the right side is free.

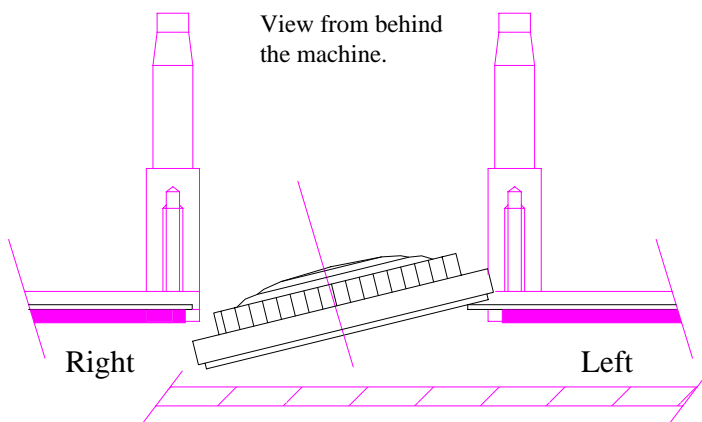

Drawing n°3

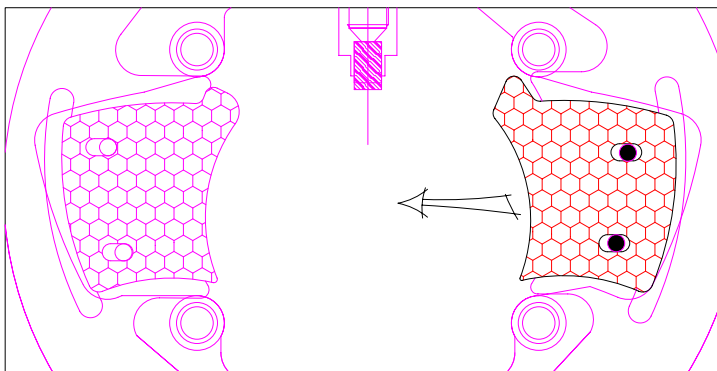

Case n°1:

1. **Uncock and disconnect the machine !!!**
2. Unscrew the two nuts M5.
3. Move the left knife inwards by 1 ou 2mm.
4. Do a testing shot.

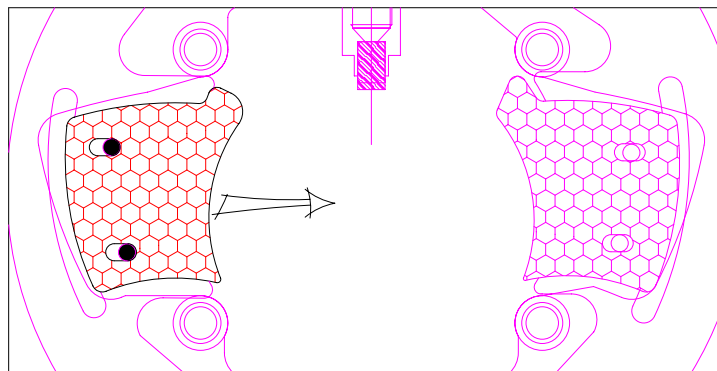

Case n°2:

1. **Uncock and disconnect the machine !!!**
2. Unscrew the two nuts M5.
3. Move the right knife inwards by 1 or 2mm.
4. Do a test shot.

Adapter kit for clay pigeon Ø60

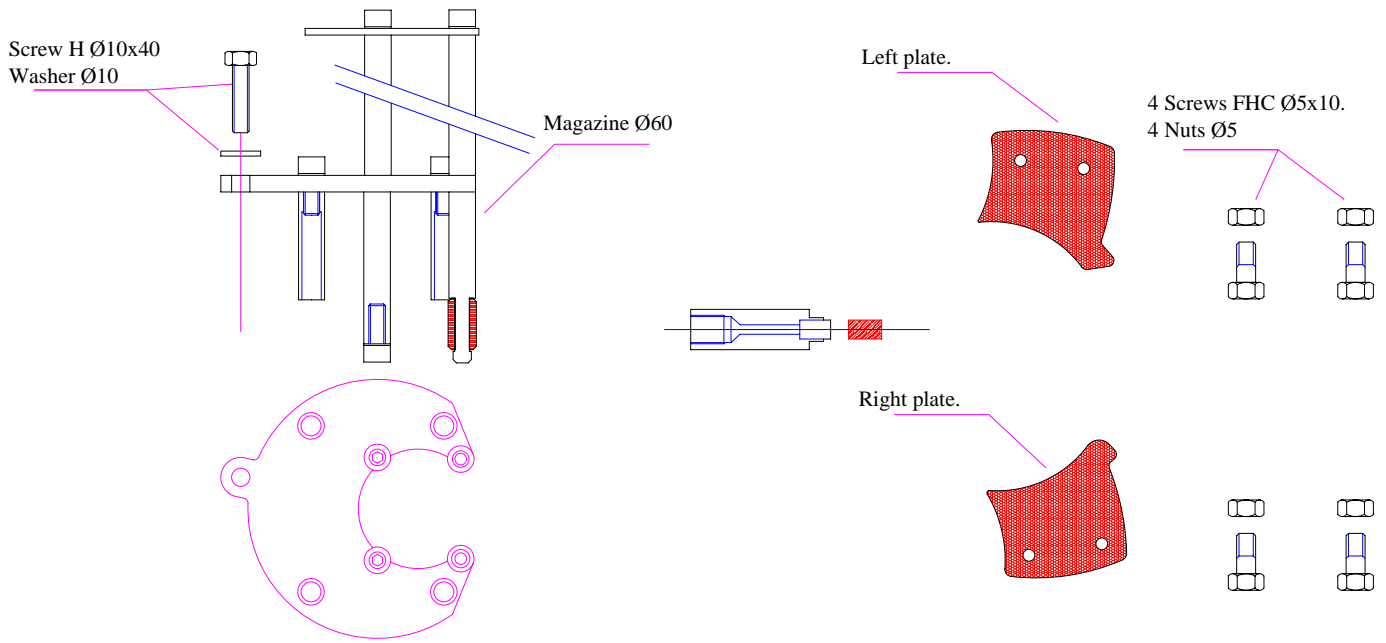

STEP N°1.

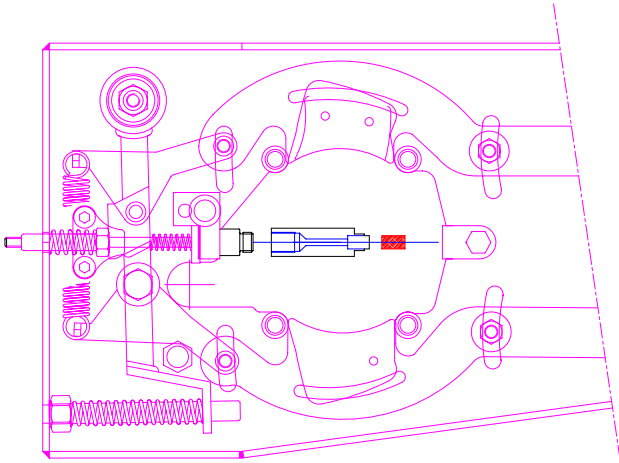

Screw the Ø60 pigeon block on the standard clay blockage (2).
As illustrated.
Never remove the rubber block.

STEP N°3.

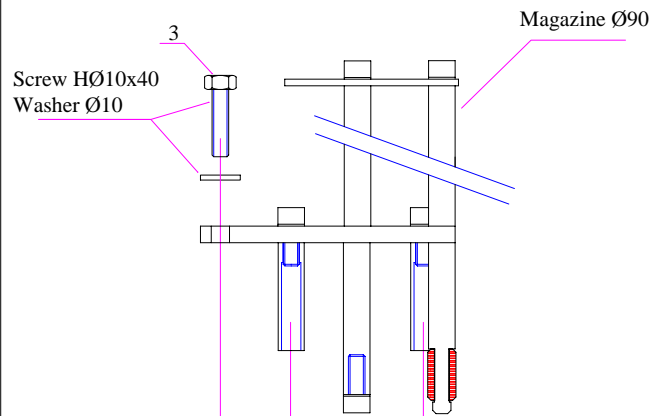

1. Position the magazine Ø90 in the place of the standard magazine.
2. Tighten the screw H Ø10x40 (3).

ETAPE N°2.

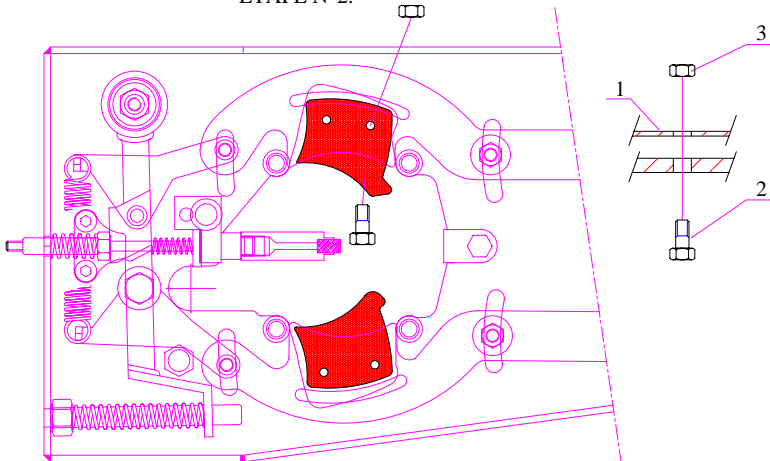

1. Position the plates (1) exactly as illustrated.
2. Screw the plates (1) with the 4 Screws FHC Ø5x10 (2).
Warning !!! Nut (3) on top.

Setting the knives when using the kit Ø60.

It is imperative to uncock and disconnect the machine before any manipulation.

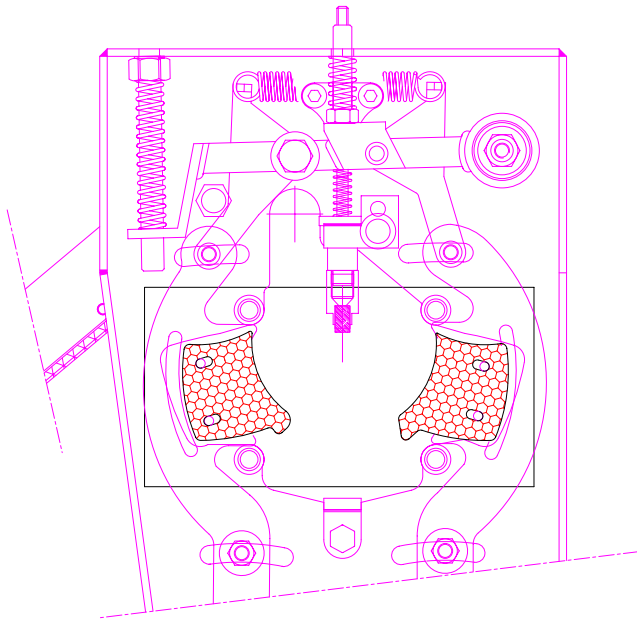

Drawing n°1

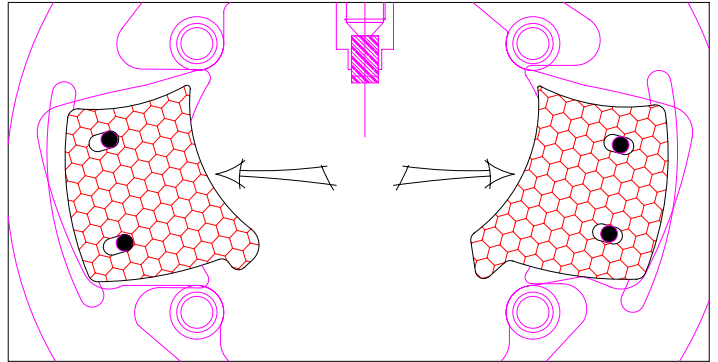

1. Put the two knives in position (as illustrated) and push them a maximum outwards.
2. Tighten the 4 nuts M5.
3. Throw a test clay, the clay should free simultaneously by the two knives and fall flat. If the clay does not fall flat, make the adjustments. (See case n°1 or case n°2)

Case n°1: The clay is held on the right side and the left side is free.

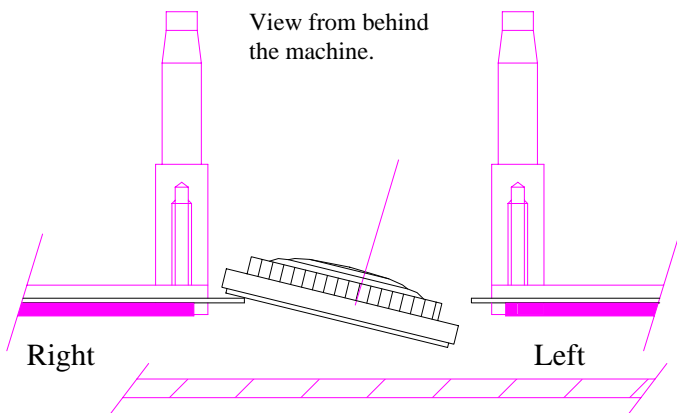

Drawing n°2

Case n°2: The clay is held on the left side and the right side is free.

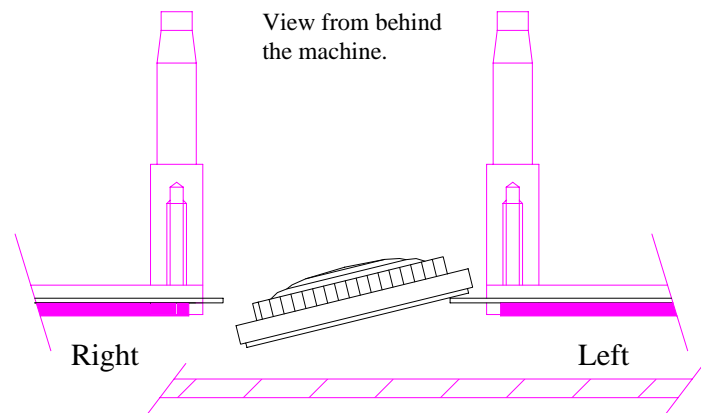

Drawing n°3

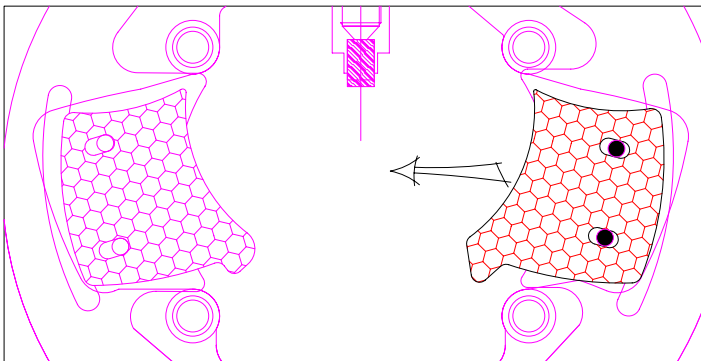

Case n°1:

1. **Uncock and disconnect the machine !!!**
2. Unscrew the two nuts M5.
3. Move the left knife inwards by 1 ou 2mm.
4. Do a testing shot.

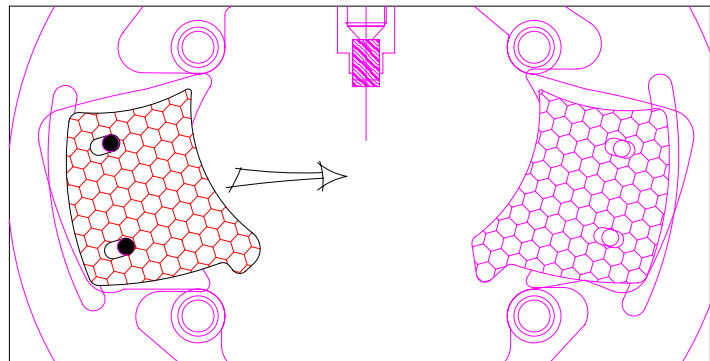

Case n°2:

1. **Uncock and disconnect the machine !!!**
2. Unscrew the two nuts M5.
3. Move the right knife inwards by 1 or 2mm.
4. Do a test shot.

Adjustment of the clay holding mechanism.

1. **Uncock** and disconnect the machine.
2. It is **imperative** to dismantle the arming spring. See Arming Spring notice.
3. Put the throwing arm in the cocked position (manually).
4. Place two clays in the magazine, position the clays towards the back of the machine.
5. Adjust the nut (17mm) to allow a space of around 1.5 mm* between the rubber block and the clay.

(Stand behind the machine and unscrew the nut 17 from left to right to reduce the space and from right to left to increase the space.)

* Space recommended by the constructor, for all types of clays.

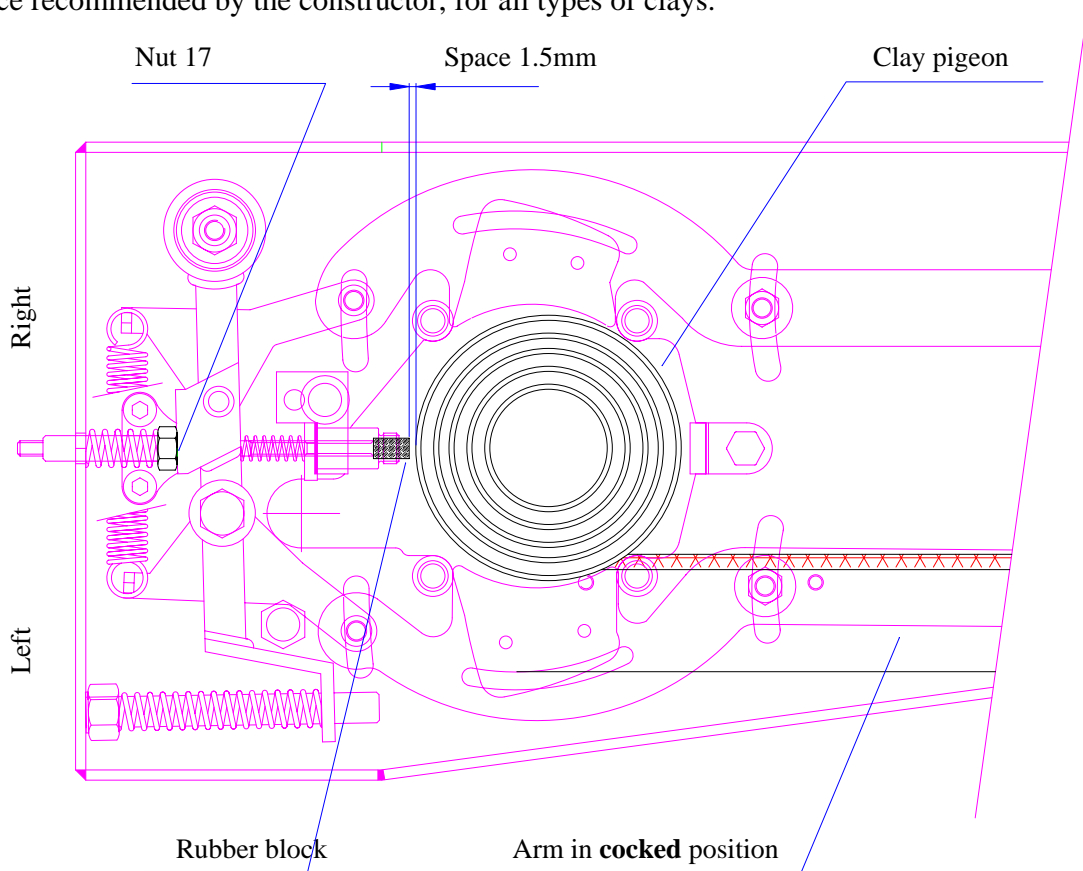

Insufficient spacing:

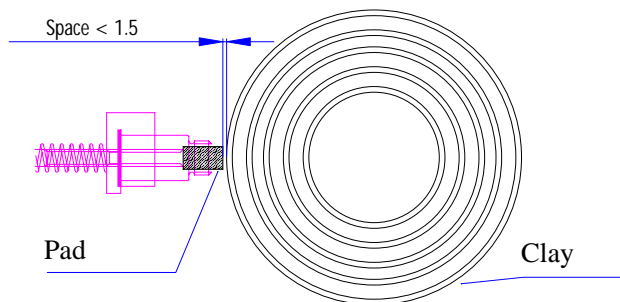

Too much pressure.
The clay pigeons may get stuck
in the magazine.

Too much spacing:

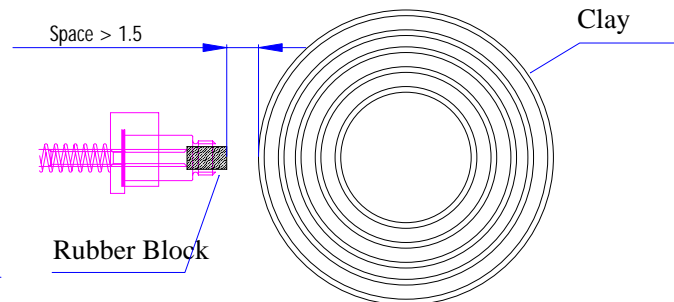

Too little pressure on the clay pigeon.
The clay pigeons may not be held in the
magazine.

Adjustment of the throwing plate.

1. **Unock** and disconnect the machine.
2. It is **imperative** to dismantle the arming spring. See Arming Spring notice.
3. Place a clay pigeon on the throwing plate.
4. Move the throwing arm (manually) level with the first adjustment screw.
5. Adjust the nut 13mm to allow for a space of around 1 mm between the arm rubber and the clay.
(Unscrew the nut 1 to reduce the spacing and tighten the nut to increase the spacing.)
6. Repeat steps 4 and 5 for screws 2 and 3.

Recommended spacing by the constructor, for all types of clay pigeons.

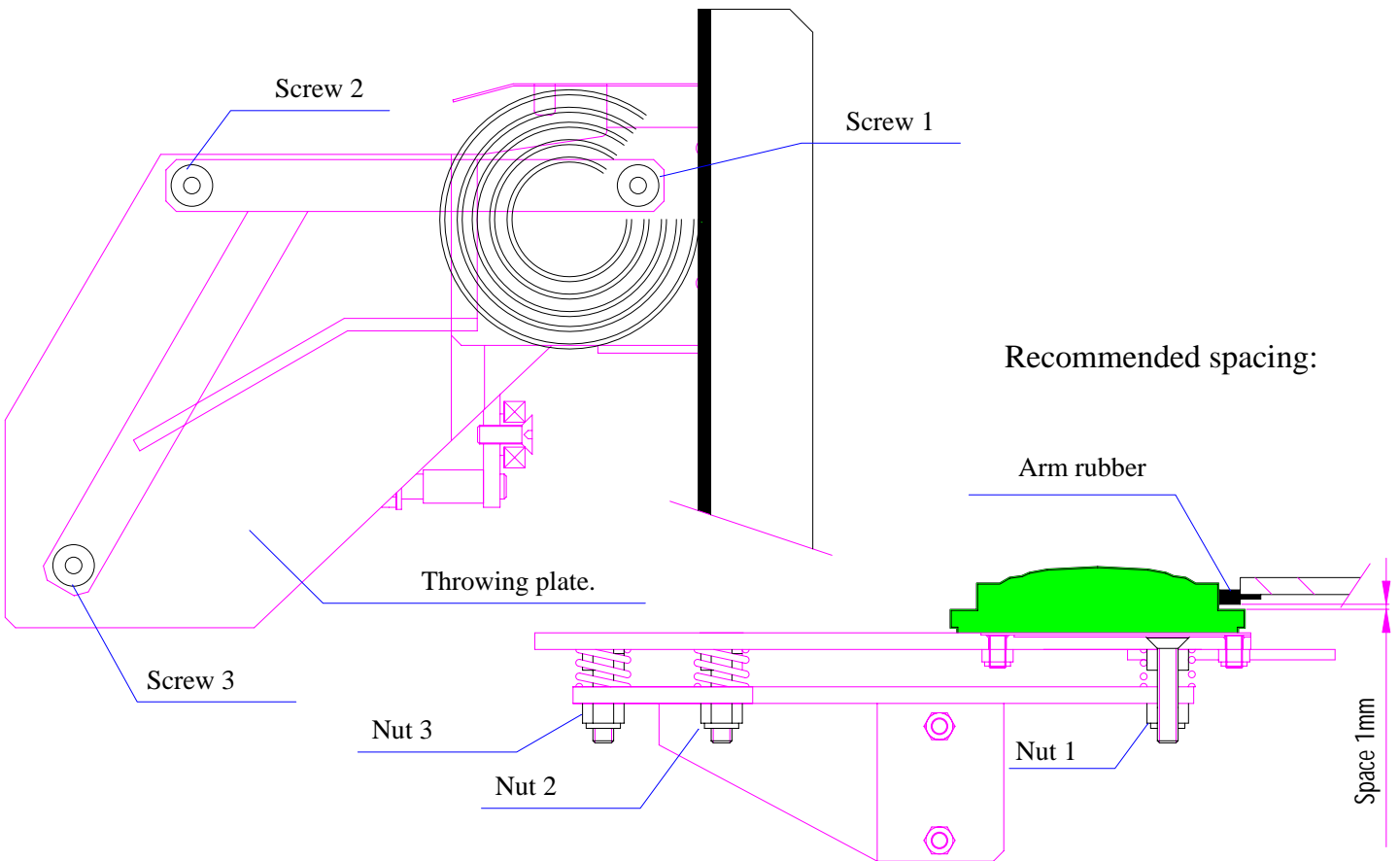

Not enough spacing:

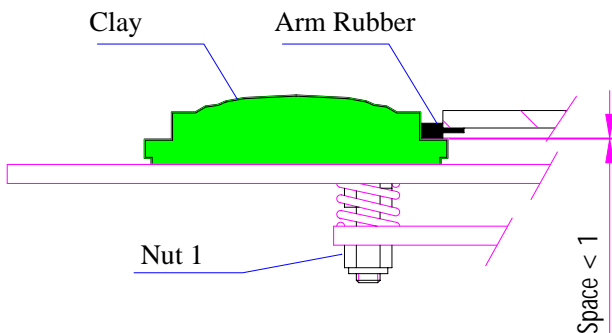

The clay is caught by the arm rubber.
The arm rubber breaks the clay.

Too much spacing:

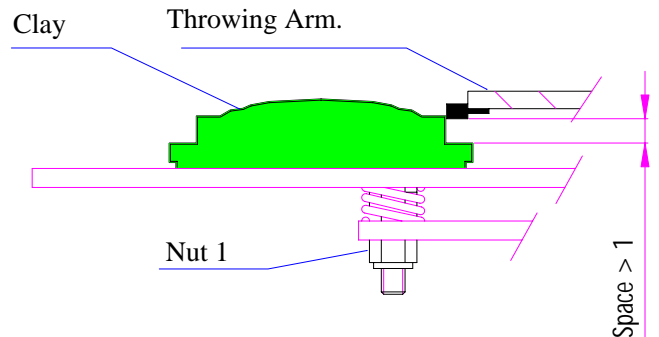

The arm rubber catches the clay too high.
The arm rubber breaks the clay.

Vertical Movement.

Warning!!! Uncock the machine before attempting any manipulation.

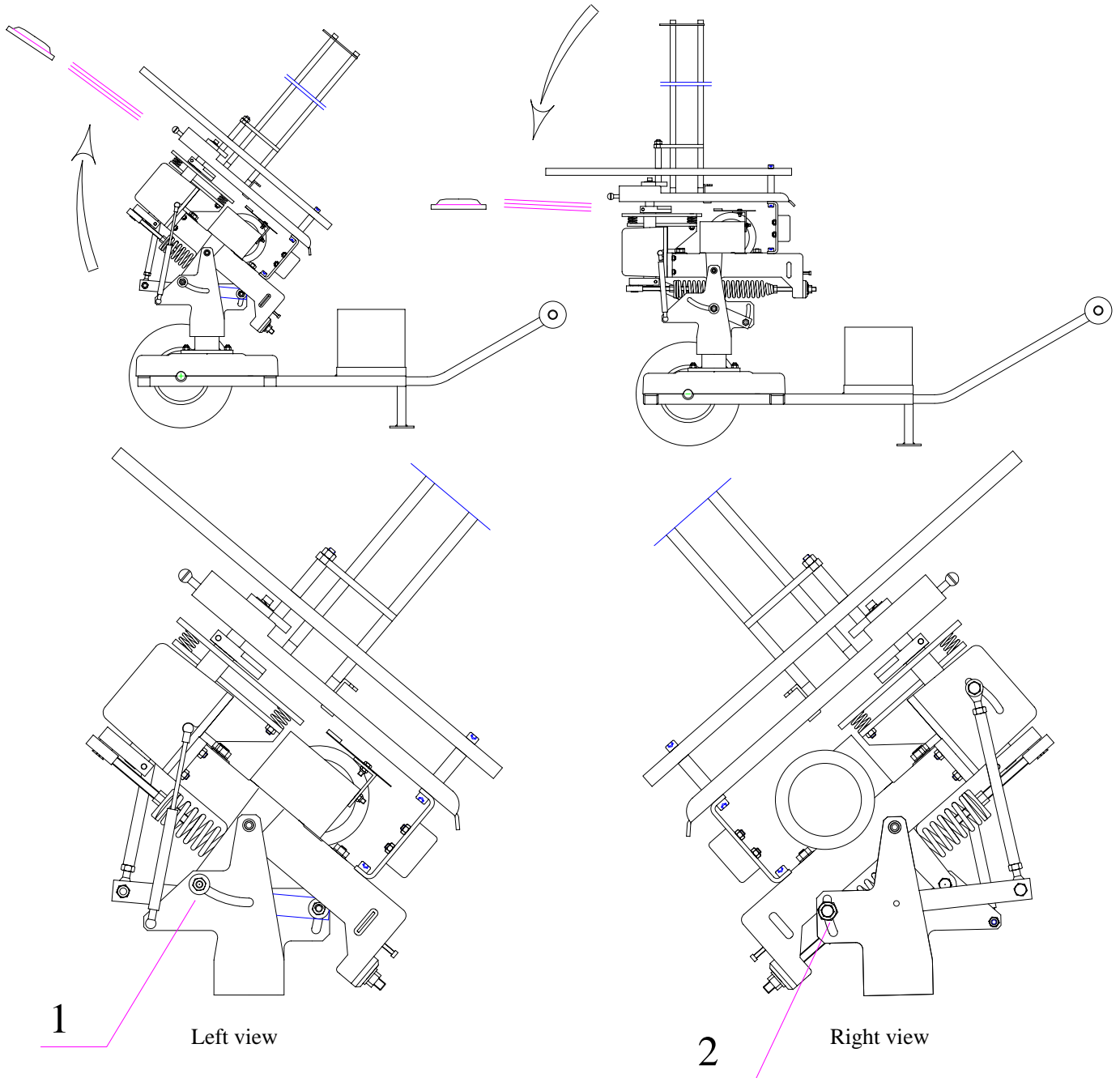

FIXED VERTICAL MOVEMENT:

To block the vertical movement, **tighten** the nut (1) and **unscrew** the nut (2).

VARIABLE VERTICAL MOVEMENT :

To use the variable vertical movement, **untighten** the nut (1) and **tighten** the nut (2).

WARNING :IT IS ESSENTIAL TO REMOVE SCREW NUMBER 2.

Horizontal Movement.

Warning !!! Uncock the machine before attempting any manipulation.

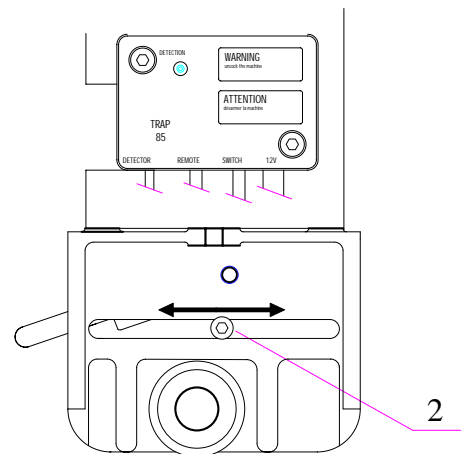
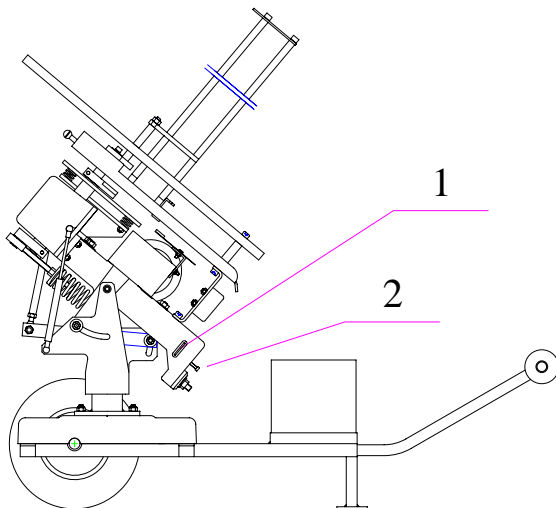
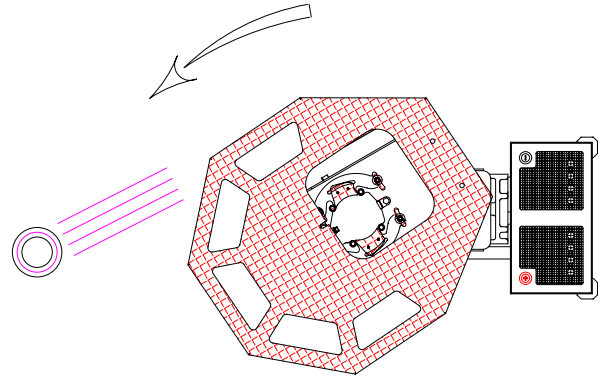
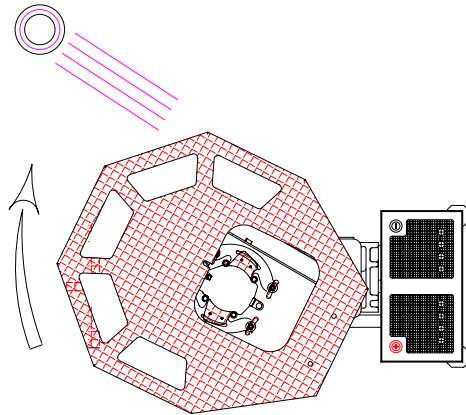

When the horizontal movement is in progress, the rod (2) moves freely across the oblong hole of the body of the machine.

View from behind the machine :

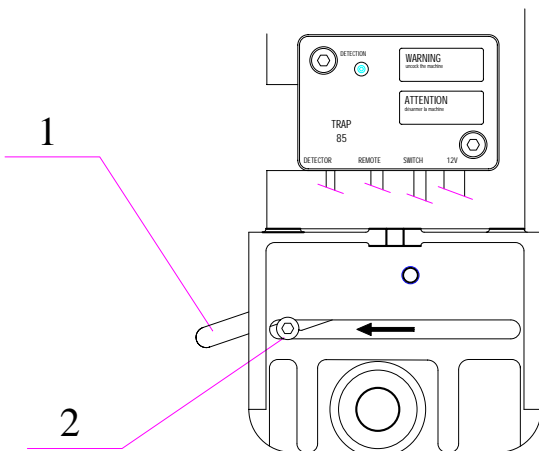

To block the horizontal movement, move the rod (2) to the extreme left of the oblong hole until this is blocked by the lever (1).

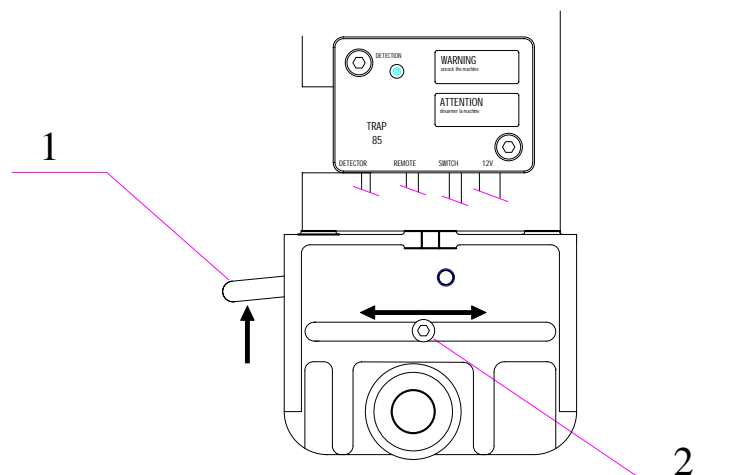

To use the horizontal movement, free the rod (2) by lifting the blocking lever (1).